

Product Catalogue

W.E. RESIDENTIAL SERIES

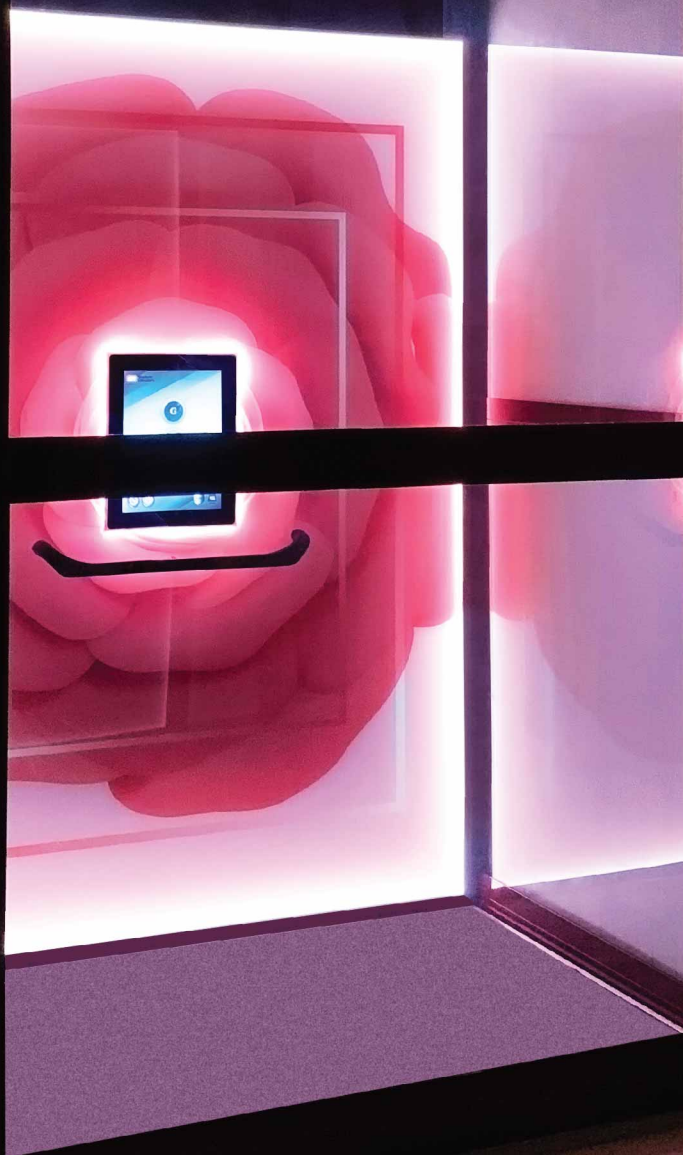

WE Western
Elevators

LIFTING YOU TO COMFORT

our story...

Western Elevators Sdn Bhd opened door for business in the year 2006. We are the pioneer for residential screw and nut elevator in Malaysia. In the short years, we have installed and maintain over 1000 units of elevators around Malaysia and Indonesia.

Over time, due to the increase in demand of residential elevators, Western Elevators Sdn Bhd aims to integrate residential elevators into people's daily life.

Understanding that every home carries a unique identity, Western Elevators Sdn Bhd offers wide selections of finishings for you to curate a personalised elevator you can truly call yours.

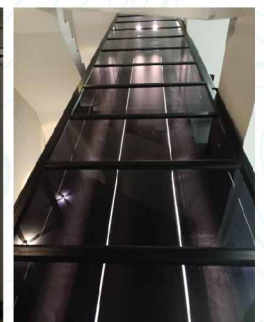
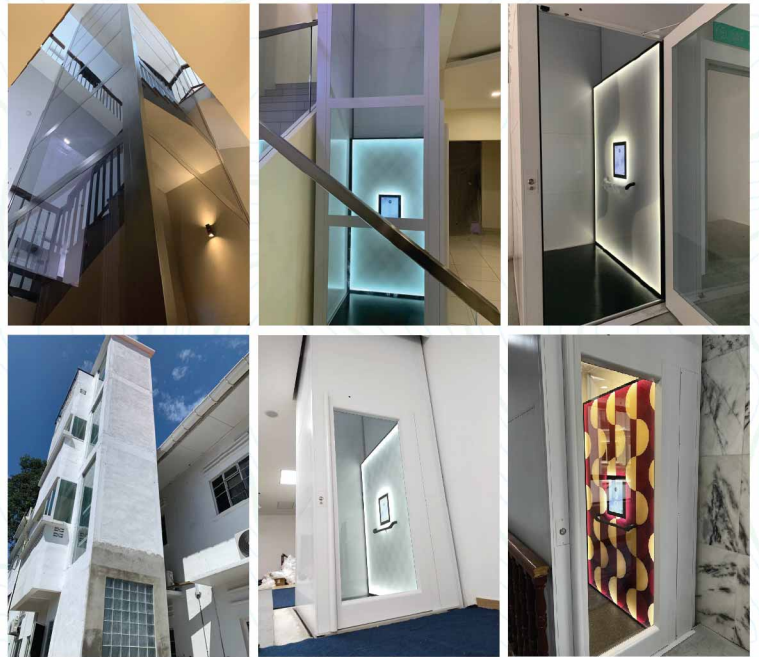

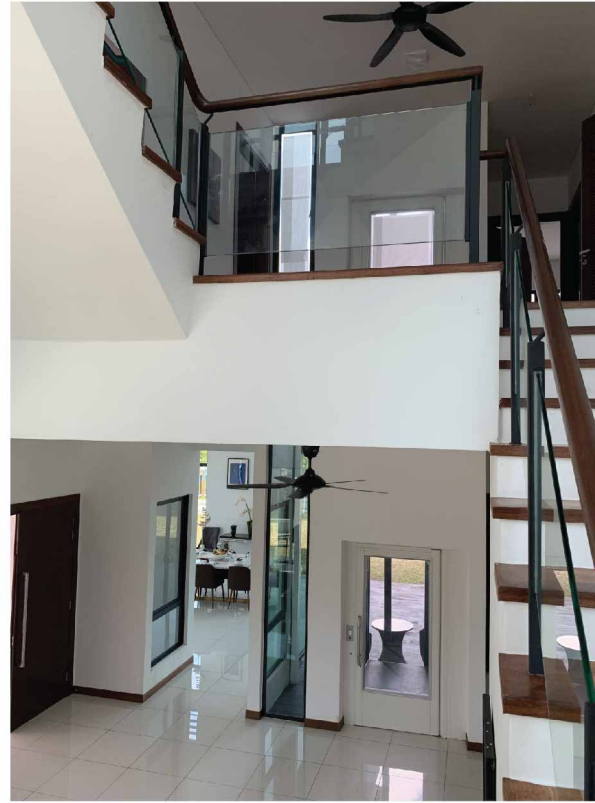
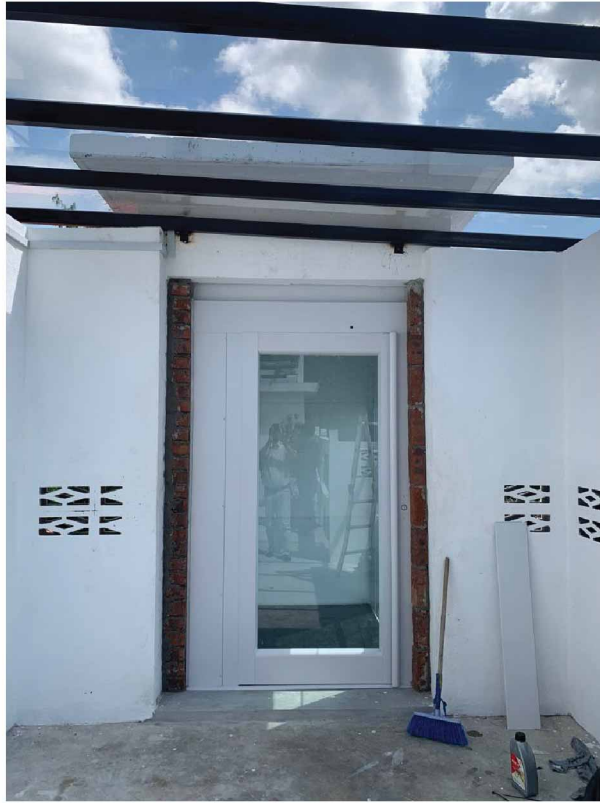

why western elevators

Our core beliefs of quality, safety, and integrity are what drive us to be the best in what we do.



Quality

Our elevators are built to be robust; constructed with style.



Safety

Our elevators not only excel in transporting our passengers, but also excel in protecting them from the unlikelihood of harm's way.



Integrity

We hold ourselves accountable to our customers for the installation, service and quality of our products every step along the way which guarantee the longevity of your comfort.

Having a W.E. Residential Series in your living space will immerse you in an exclusive sense of ownership that will be your source of pride and joy.

Introducing to you **W.E.Residential Series**

Each and every elevator is tailored specially for you in terms of functionality and aesthetics, inside and out.

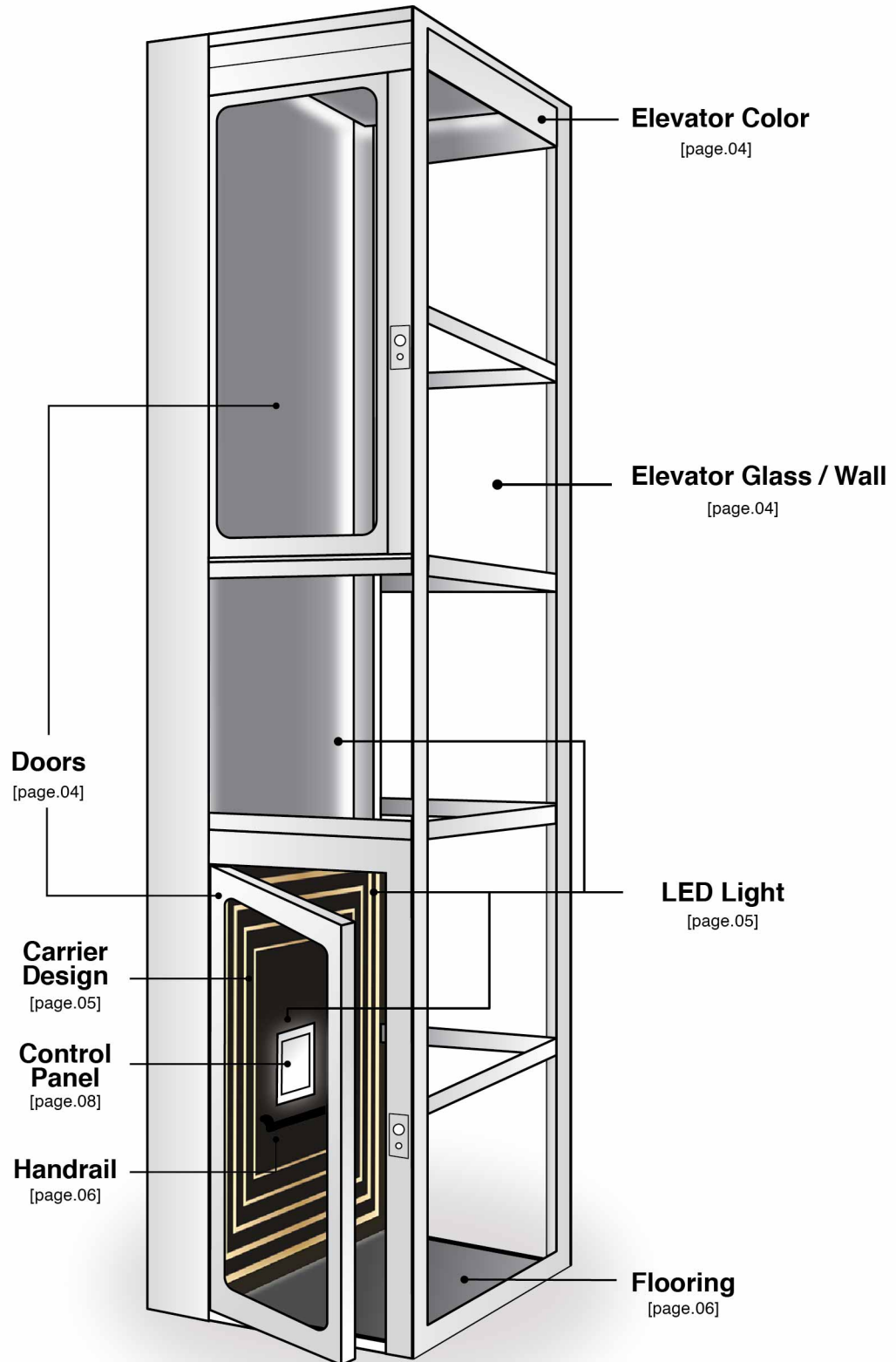

*Images are for illustration purposes only.

External Elevator Options

W.E. Residential Series are powder coated in 4 standard colors – special formulated white, jet black, wine red and beige. The shaft finishing of the elevator is versatile as you can place the door on any side of the elevator. You may also choose the finishing of the shaft with fully covered, semi-glass or fully glass finishing. Our elevator is suited to be installed indoor and outdoor.

*Available in other colors.



Color: Jet Black
Full Glass

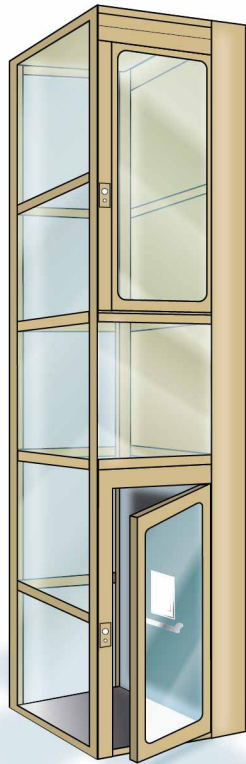

Color: Beige
3 Sides Glass



Color: Wine Red
2 Sides Glass

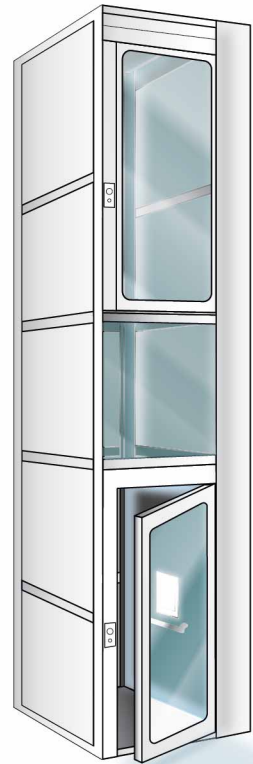

Color: White
1 Side Glass

Glass

3 different types of tempered laminated glass



Clear Glass



Tinted Glass



Frosted Glass

Landing Door

To complete your elevator, each floor comes with a full vision door. Each door is powder coated with the same color as the shaft you selected. Each door comes with a beautifully integrated door handle that enhances the aesthetics of your elevator .

*Images are for illustration purposes only.

Internal Carrier Options

The carrier consists of a L-Shaped carrier which is fully equipped with high quality materials; aluminium handrail electroplated for maximum corrosion resistance, wide selections of full height carrier designs to match your tastes, and a digitalised control operating panel to mobilise you everyday.

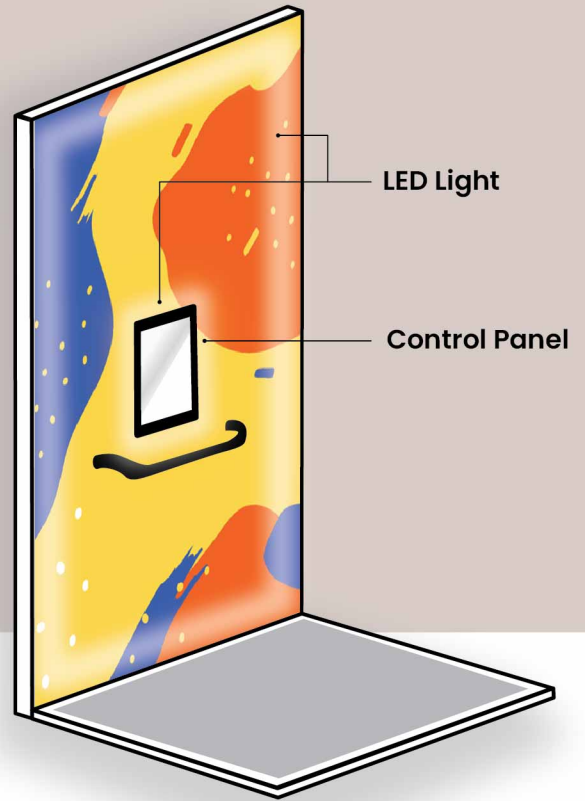

**8-CARRIER
DESIGNS FOR
SELECTION**

Carrier Designs

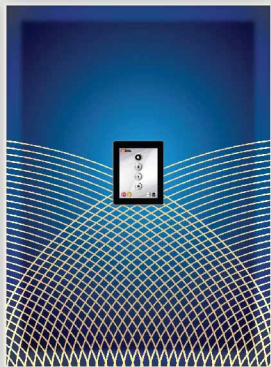

Horizon



Tessellate



Marmo

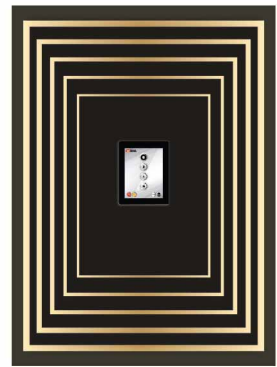

Jewel



Albus



Matisse



Rosé

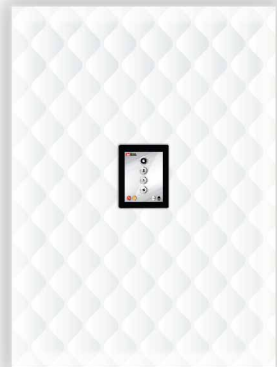

Plain Jane

*Images are for illustration purposes only.

Handrail

Each carrier comes with a carefully installed aluminium handrail. Each handrail is electroplated for maximum corrosion resistance to ensure the elevator's longevity and durability.



Flooring

Each carrier comes with anti-slip and anti-scratch vinyl flooring. The carefully selected designs will blend in seamlessly with any carrier designs or shaft finishing you selected.



Black Galaxy



Mars



Milky Way



Grounded Earth

*Images are for illustration purposes only.

Carrier Size Options

W.E. Residential Series is available in 2 standard sizes WE300 and WE400. Staying true to the core mission of W.E. Residential Series, we also provide custom-made shafts to suit your requirement.

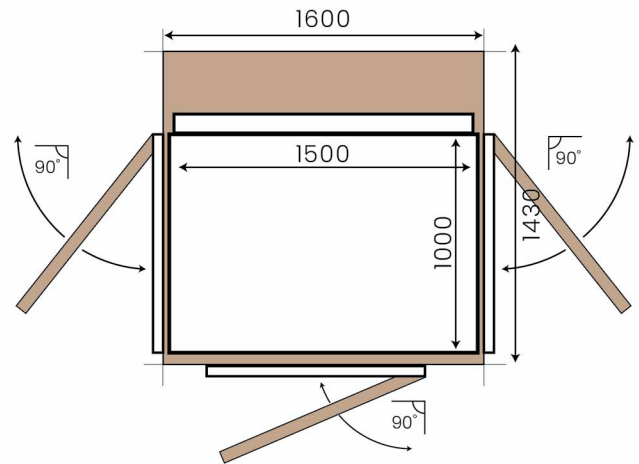
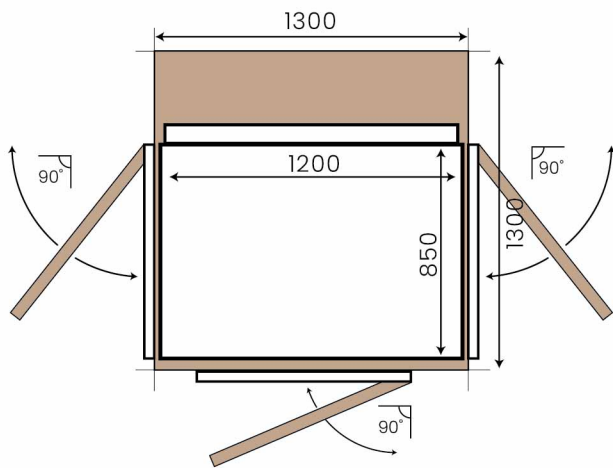
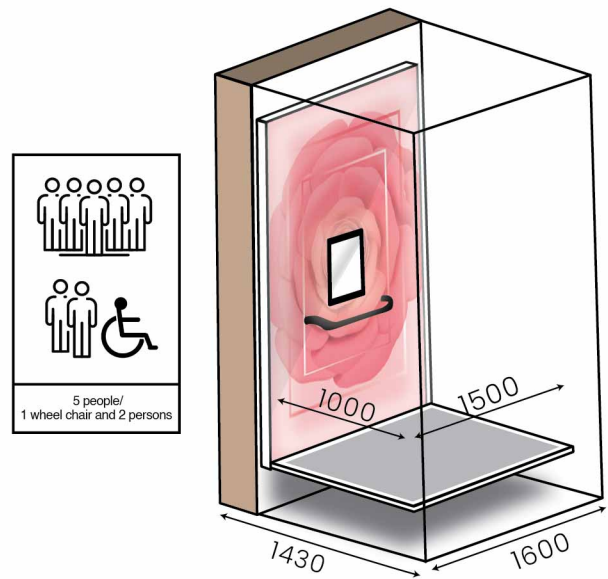
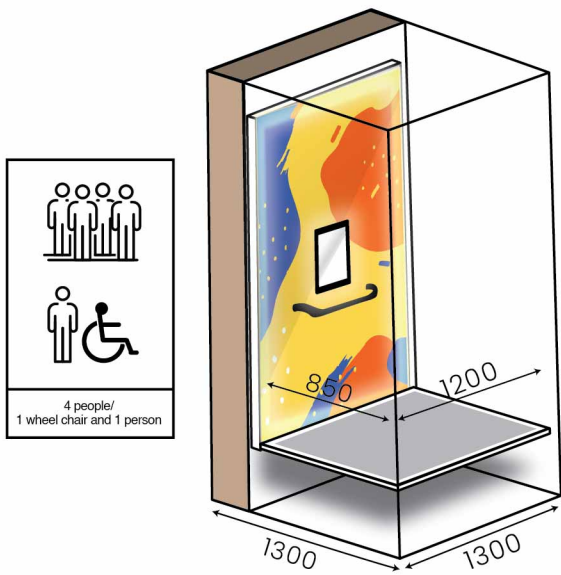

Model-WE300 | 1300 mm x 1300 mm

* Custom sizes are available.

Model-WE400 | 1430 mm x 1600 mm

* Custom sizes are available.

Installation Requirement

Having your elevator installed is a straightforward process. The details and minimum requirements for a seamless installation are listed here:

Carrier Size	WE 300	WE 400
Rated Load	300 kg	400 kg
Structural Opening	1300 x 1300mm	1430 x 1600mm
Carrier Size	850 x 1200mm	1000 x 1500mm
Door Size	750 x 2000mm 650 x 2000mm	900 x 2000mm 950 x 2000mm

Installation Environment	Indoor or Outdoor
Drive System	Screw and Nut Driven
Travel Height	Up to 6 stops
Top Height	min. 2400mm
Pit Requirement	50mm or install directly on the floor with a ramp
Destination and Call Button	Automatic one touch control system
Rated Speed	0.15m/s or 9m/m
Electrical Requirements	3ph 415v 16A 5 core

Control Panel Features

W.E. Residential Series is designed with the most sophisticated safety measures to ensure that they are user-friendly - a **worry-free experience**.



Smart Control Panel
 WE Residential Series is the only home elevator that is equipped with a **Smart Control Panel**. This system is able to display error or fault which will allow for quick troubleshooting.

Landing Indicator

This indicates your current location level.

Destination Button

Button of the selected destination will light up as the elevator ascend or descend.

Alarm Button

In the unlikely event that the elevator comes to an unintended stop, this allows the users to alarm dwelling members.

Emergency Stop Button

To halt elevator operation when necessary.

Auto / Manual Button

User may choose to descent or ascent during power failure.

Overloaded Icon

When elevator is overloaded with intended weight, the icon will lit up and the elevator will not operate.

*Images are for illustration purposes only.

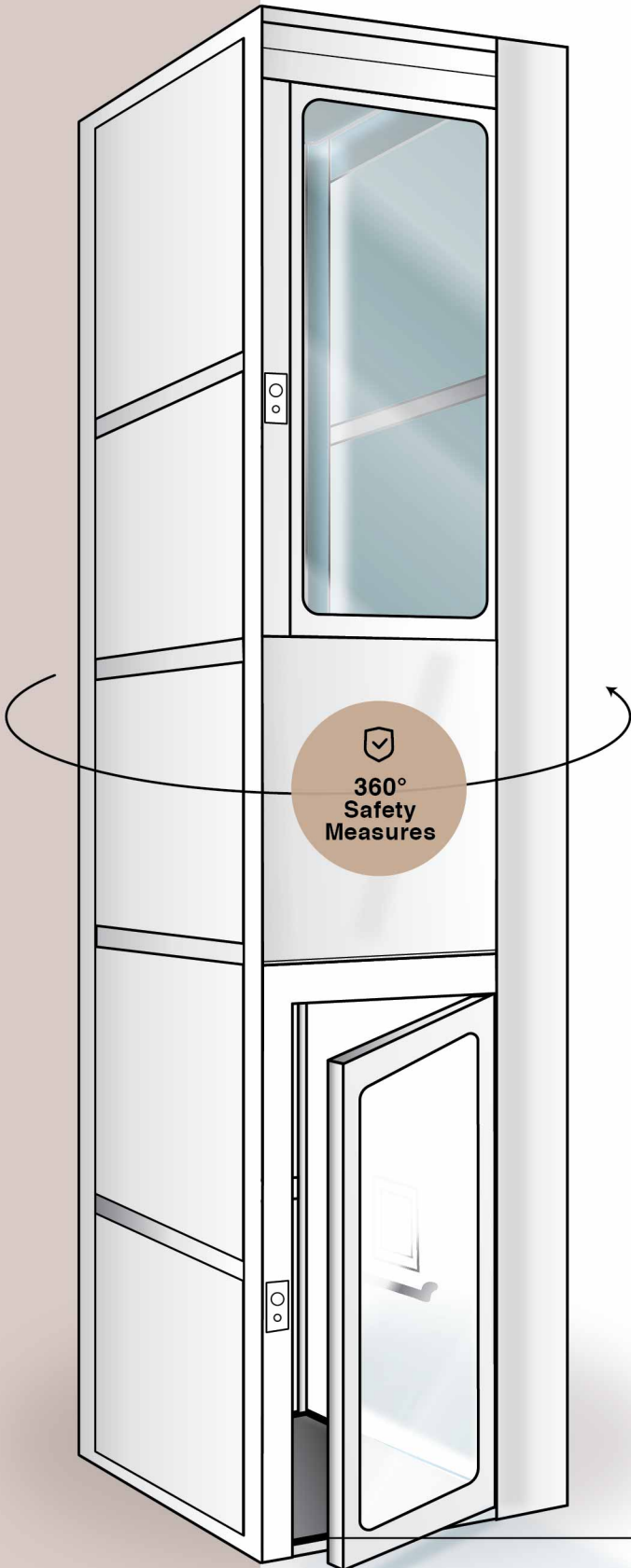

Safety Highlight

As safety is extremely important to us, W.E. Residential Series also equipped with **360° safety measures**.

→ **Door Key Lock**

Every elevator will come with a key switch which enables you to lock the elevator for safety purposes.

→ **Safety Bars**

Safety bars are installed across all edges of the carrier, stopping immediately if an object gets caught in one of the bars.

→ **Interlock System**

Doors on all levels will be locked with interlock system when elevator is in use.

→ **Self-Rescue Mechanism**

During power failure, elevator carrier will automatically descent to the nearest level and the landing door will be unlocked.

→ **Travel Accuracy**

Over and under travel safety switch to ensure that the elevator travels within the permissible traveling distance.

→ **Others**

- Overload Detection
- Audible Alarm
- Emergency Lighting
- Safety Nut With Electric Switch
- Emergency Door Key
- Emergency Stop Button

→ **Safety Bar**

*Images are for illustration purposes only.

Product Summary

Having your elevator installed is a straight-forward process. Here is an overview of WE Residential Series.

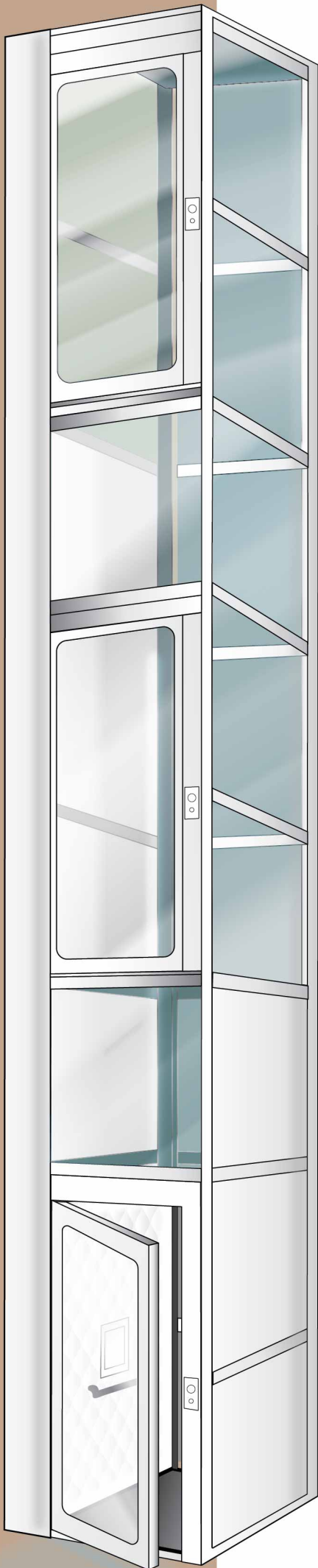

[3 Sides]
Glass

Glass

3 different types of tempered laminated glass



Elevator Color

Powder coated in 4 standard colors



[2 Sides]
Glass

Handrail

Each carrier comes with a carefully installed aluminium handrail



Flooring

Each carrier comes with anti-slip and anti-scratch flooring

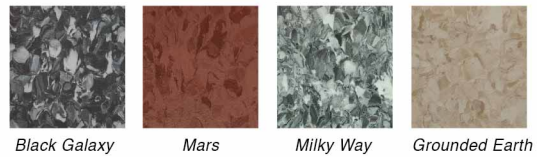

[1 Side]
Glass

Carrier Design

8 carrier designs for selection.

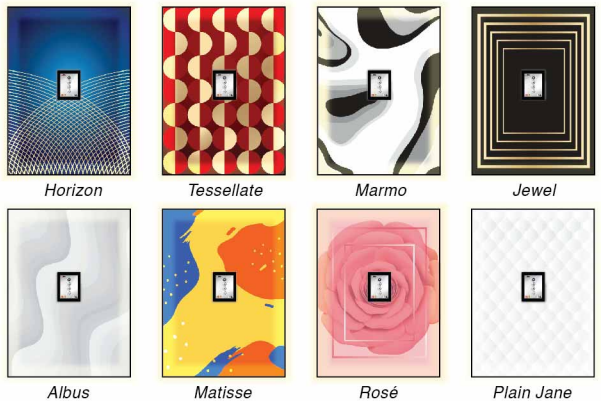

Elevator Color: White



LIFTING YOU TO COMFORT



SCAN HERE TO
OUR WEBSITE

sales
person



more
info

📍 **Western Elevators Sdn Bhd** (948472-U)
No 12A, Jalan 17/1, Seksyen 17,
Petaling Jaya, 46400, Selangor.
✉ sales@westernelevators.com.my
☎ +603-7955 0088, 7651 7896
🌐 www.westernelevators.com.my